



The SABER line of heavy-duty, precision paper cutters combines proven mechanical design - manufactured to ISO-9001 standards, with state-of-the-art electronics. Incorporating the knowledge gained in over 20,000 microcut installations worldwide, the system offers a wide array of programming options and features, presented in an intuitive, easy to use format.



Precision Cutting

The knife bar is drawn through the pile, pulled from both ends, insuring stable, precise cutting with even the most difficult stock.

Back Gauge Control

A ball bearing leadscrew and linear guide are integral to back gauge control. Together with SABER's patented DC drive system, smooth and accurate positioning is assured at all speeds.

World-Class Controls

The multi-lingual, active matrix touch screen guides the operator through all operations. Real time data collection, network ready interface, and a USB connection for on-site data input and retrieval are all standard.

Quality Construction & Ease of Maintenance

Chromed main side tables, a one piece base which integrates table supports, and computer controlled lubrication are but a few of the features that add up to 11,000 pounds of precision machinery and years of trouble free operation.

Operator & Machine Safety

SABER is designed to comply with the new CE safety standards, acknowledged as the most stringent in the world. Some 150 machine functions are monitored over 1000 times a second, with duplicity in all circuits.

Saber Dimensions

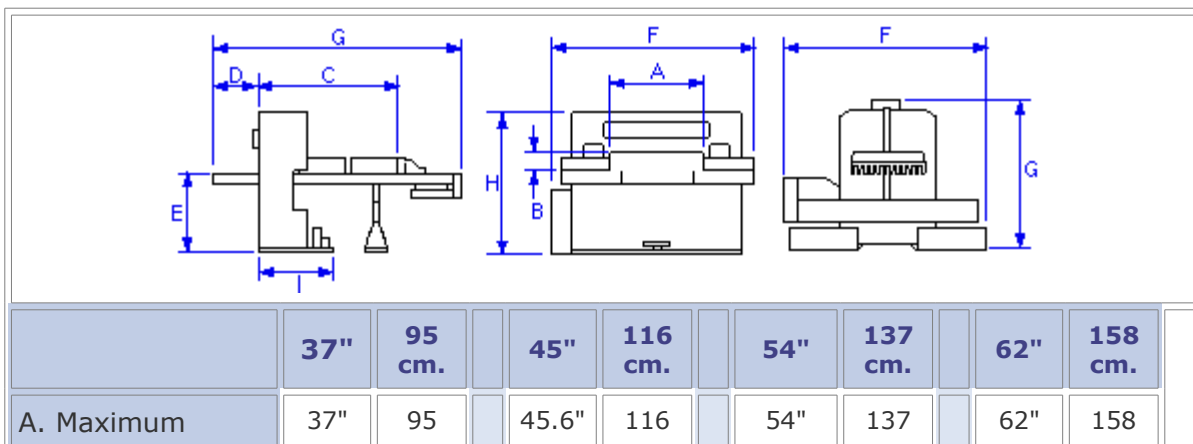

Cutting Width		cm.		cm.		cm.		cm.
B. Maximum Pile Height without false clamp	6.0"	15.2 cm.	6.5"	16.5 cm.	6.5"	16.5 cm.	6.5"	16.5 cm.
C. Maximum Working Depth Rear Table	38.6"	98 cm.	45.6"	116 cm.	58.25"	148 cm.	65"	165 cm.
D. Maximum Working Depth Front Table	26.3"	67 cm.	28"	71 cm.	28"	71 cm.	28"	71 cm.
E. Table Height	35.6"	90.5 cm.	37.5"	95.2 cm.	37.5"	95 cm.	37.5"	95 cm.
F. Overall Machine Width	97"	246 cm.	108"	275 cm.	116"	295 cm.	140"	354 cm.
G. Overall Machine Length	91"	231 cm.	100"	254 cm.	118"	300 cm.	142"	360 cm.
H. Overall Machine Height	61"	155 cm.	66"	168 cm.	66"	168 cm.	70"	178 cm.

Saber Power

	95		116-137		158	
Electrical Protection	Thermal Breakers (Hp)	(Kw)	Thermal Breakers (Hp)	(Kw)	Thermal Breakers (Hp)	(Kw)
Main Motor	5 Hp.	3.75 Kw.	5 Hp.	3.75 Kw.	7.0 Hp.	5.5 Kw.
Back Gauge Motor	.5 Hp.	0.4 Kw.	.5 Hp.	0.4 Kw.	1.0 Hp.	.75 Kw.
Air Table Motor	.75 Hp.	.55 Kw.	1 Hp.	.75 Kw.	1.0 Hp.	.75 Kw.
220/380 VAC +/- 10% 50/60 Hz 30AMP	Standard		Standard		Standard	

Saber Specifications

Specifications & Technical Data	37"	95 cm.	45"	116 cm.	54"	137 cm.	62"	158 cm.
Minimum Cut with false clamp on	2.5"	63. cm.	3"	7.5 cm.	3"	7.5 cm.	3"	7.5 cm.
Minimum Cut without false clamp	.8"	2 cm.	1.3"	3.3 cm.	1.3"	3.3 cm.	1.3"	3.3 cm.
Maximum Clamp Pressure	8800 lbs.	4000 Kg.	9900 lbs.	4500 Kg.	9900 lbs.	4500 Kg.	13200 lbs.	6000 Kg.
Maximum Back Gauge Speed	12" sec	30 cm sec	12" sec	30 cm sec.	12" sec.	30 cm sec.	12" sec	30 cm sec
Net Weight with full oil tank	7040 lbs.	3200 Kg.	10,100 lbs.	4600 Kg.	11,400 lbs.	5200 Kg.	13200 lbs.	6000 Kg.

