

# CHALLENGE PRODUCTS



## TITAN® PAPER CUTTERS





## Choose the Leader

Experience the accuracy, speed, and versatility of Challenge cutters — designed to save time and money on your post-press bindery jobs. Part of the Challenge team of cutters, drills, folders, and other bindery equipment . . . all crafted with pride in the U.S.A. since 1870.

# Challenge Titan Series Paper Cutters

The Titan series paper cutters continue the Challenge tradition of innovation, delivering large cutter features in **20"** and **26½"** cutting widths with programmable backgauge control. The Titan paper cutters offer many features first made popular on our larger cutter models.

## Programmable Features . . .

- Menu-Driven LCD Screen
- Computer Backgauge Control
- LCD Digital Backgauge Position Indicator
- Variable Mode Data Entry
- 99 Channel, 9,801 Total Cut Memory
- Memory Lockout
- An Industry First — Patent-Pending, Variable-Speed Pinpoint Backgauge Control
- Push-Out Function
- Computer Diagnostics

## Designed for Convenience . . .

Thanks to Challenge's innovative computer engineering, the Titan models offer a **99-channel memory** that stores up to **99 cuts per channel**. Subsequent channels can be combined to increase program size.

The Titan's unique control system permits **variable mode data entry**. Enter data in inches (to 0.001"), millimeters (to 0.01 mm), or fractions (to nearest 1/64"). You can also **convert data** from one system to another with just the touch of a button!

**Menu-driven set-up** and a **light touch electronic keypad** combine to simplify programming or editing each job. Channels, cut dimensions, and backgauge position are displayed on the LCD screen.

## Speed . . .

The keypad features an advanced, new, patent-pending, **variable-speed pinpoint backgauge control** to quickly position stock. Depending on the portion of the pin-point control you touch, the backgauge moves forward or backward at varying speeds. Or, simply type in the desired position and press the "Send" key. The computer positions the backgauge prior to each cut, for maximum productivity.

## Control . . .

The **line-light cut position indicator** projects a line of light to quickly and accurately position each cut, and aid programming of multiple-cut jobs.

For pre-cut clamping, such as for holding slick stock or verifying cut position, the **mechanical foot pedal** gives the operator complete control of the clamp.

## Durability . . .

The Titan's solid **cast iron and steel construction** provides maximum durability. Knife changing is easy and quick, thanks to the slotted knife bar design. **False clamp plate** installation and removal is just as convenient, because it's handled from the front of the machine.

## Flexibility . . .

The system's single **hydraulic motor** powers both clamp and knife, without any loss of power or accuracy. Clamp pressure is adjustable, so clamping force can be changed to match specific job requirements. The **electronic clamp pressure control** (standard 265/optional 200) can set clamping pressure from the "Send" screen. During a cut cycle, hydraulic clamp pressure is activated. After increasing to the selected setting, it is maintained throughout each cycle. Hydraulic operation assures more power, less stock spoilage, less maintenance, and greater reliability. After a few minutes of inactivity, the Titan switches into an energy-conserving standby mode.

## Safety . . .

Choice of equipment includes a **plexiglas safety shield** or a **light curtain** to guard the cutter opening.

The **plexiglas safety shield** covers the entire front table and after positioning your stock must be lowered before pressing the two cut buttons to activate the hydraulic system.

The **light curtain** includes self-monitoring, self-checking beams to insure the highest degree of safety for the operator. This system provides the greatest productivity as the operator only has to push the two cut buttons after positioning stock.

A dedicated **push-out key** moves stock forward, allowing the operator to turn or remove jobs without placing hands in the clamp and knife area. To assist in stock alignment and removal, a wooden jogging aid is supplied with each Titan cutter. **NOTE: An operator should never place hands under the clamp or knife.**

In addition to the rear plexiglas table cover, a slot closure device covers the table opening required for backgauge movement.



## . . . and Logic

An advanced computer program monitors and diagnoses cutter operations. Sophisticated sensor arrays detect backgauge position and mechanical cutting sequences. If a problem is detected, the computer will shut down the machine, and display an error message to simplify troubleshooting.

# TITAN® 200 & 265 CUTTERS

## Standard Features . . .

- 20" or 26½" Cutting Width
- Hydraulic Clamping and Cutting
- Adjustable Clamp Pressure
- 3¼" Clamp Opening (Titan 200)  
4" Clamp Opening (Titan 265)
- Mechanical Foot Pedal Clamping
- Line-Light Cut Position Indicator
- Safety Devices – Choice of Light Curtain (shown on cover) or Plexiglass Safety Shield (shown at right)
- Plexiglas Rear Table Safety Shield
- Heavy Duty Casters (Titan 200 only)
- Lighted Work Surface
- Cast Iron and Steel Construction
- 12" x 19" Side Tables (available as an option on Titan 200)
- 1½ H.P., Single Phase, 230 Volt Motor (Titan 200)  
5 H.P., Three Phase, 208/230 Volt Motor (Titan 265)

Each cutter includes two knives, three plastic cutting sticks, jogging aid, tool kit, and operator's manual.

## Optional Equipment . . .

- 5 H.P., Single Phase, 208/230 Volt Motor (Titan 265)
- False Clamp Plate
- Backgauge Book Guides (helps hold stitched booklets for trimming)



*Titan 200 above is shown with the plexiglas cut control safety shield. (Titan 265 on cover is shown with the Category 4 light curtain safety beams)*



Versatile control panel with **variable mode data entry** allows you to work in decimals (inches or mm) or fractions (to 64ths) and convert from one system to another at the touch of a button.

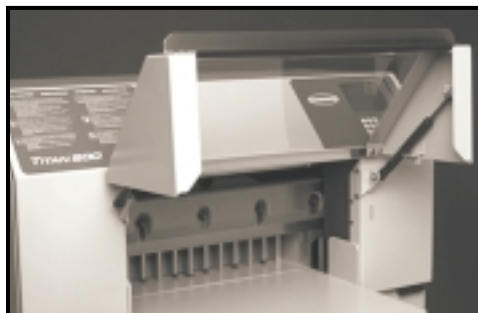

Choose from the **light curtain safety beam** (shown on cover) or the front table **plexiglas safety shield**. (The hydraulic system operates only after closing the cover and pressing the cut buttons.)



The **LCD screen** summarizes job names, displays programming, and lets you direct other machine functions.



# TITAN CUTTERS

## Specifications

### Titan Paper Cutters

#### Titan 200

#### Titan 265

#### CUTTING

Maximum Cutting Width	20"/50.8 cm	26½"/67.3 cm
Minimum Cut: without false clamp plate	½"/13 mm	⅝"/16 mm
with false clamp plate	1⅞"/48 mm	1⅞"/48 mm
Maximum Cut Depth	20"/50.8 cm	28"/71.1 cm
Clamp Opening: without false clamp plate	3¼"/8 cm	4"/10.2 cm
with false clamp plate	3"/7.6 cm	3¾"/9.5 cm
Clamping Method	Hydraulic & Manual	Hydraulic & Manual
Backgauge Control	Power	Power

#### DIMENSIONS

Table Space: in front of knife	15¼"/39 cm	18½"/47 cm
behind knife	20"/51 cm	28"/71.1 cm
Overall Height	53"/135 cm	58⅞"/148 cm
Overall Width	36"/91 cm	46¼"/117 cm
Overall Length	49⅝"/126 cm	64½"/164 cm
Will Pass Thru Door	36" / 91.4 cm (table removed – minimum opening required) 30" / 76.2 cm (table, treadle & front shield off)	
Net Weight (approximate)	795 lbs/361 kg	1680 lbs/762 kg
Shipping Weight (approximate)	920 lbs/418 kg	1900 lbs/861 kg

#### ELECTRICAL

##### Titan 265 Motor



5 H.P., 208/230 Volts, 60 Hz, 3 Phase, AC, 25 Amps.  
Service size 30 Amps. (standard configuration)  
5 H.P., 208/230 Volts, 60 Hz, 1 Phase, AC, 30 Amps.  
Service size 40 Amps. (optional configuration)

##### Titan 200 Motor



1½ H.P., 230 Volts, 60 Hz, 1 Phase, AC, 12 Amps.  
Service size 15 Amps. Requires receptacle type:  
NEMA 6-15R or 6-20R.

Challenge reserves the right to make changes to any product or specification without notice and without incurring responsibility to existing units.

© Challenge and Titan are registered trademarks of The Challenge Machinery Company. All rights reserved.

Symbol	Titan 200(inch/cm)	Titan 265 (inch/cm)
A1	53.0 / 135	64.5 / 164
A2	49.0 / 124	same as A1
B	53.0 / 135	58.188 / 148
C	36.0 / 91	46.25 / 117
D	58.0 / 147	64.5 / 164
E	58.0 / 147	64.5 / 164
F	74.0 / 188	90.0 / 229

**Machine Dimensions:** AxBxC  
**Machine Dimensions with Side Table Extensions:** DxBxC  
**Operating Area:** ExF  
**Overall Maintenance Area:** ExF

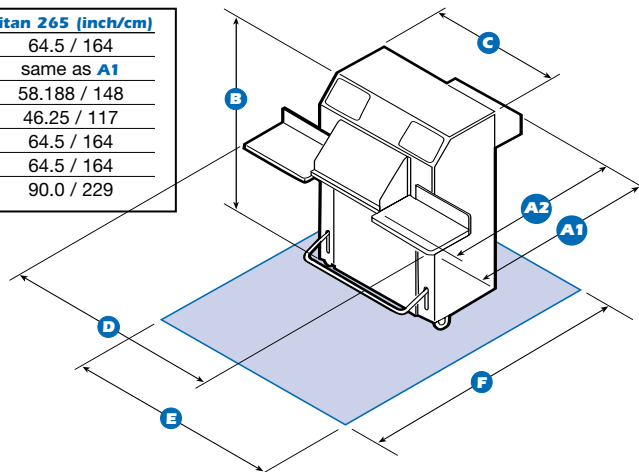

For information on this and other Challenge products, call your local Challenge dealer or for the dealer nearest you contact:

**The Challenge Machinery Company**  
 6125 Norton Center Drive, Norton Shores, MI 49441 U.S.A.  
**231-799-8484**  
[www.ChallengeMachinery.com](http://www.ChallengeMachinery.com)